

# Visual Signals - Industrial

## ROTATING BEACONS

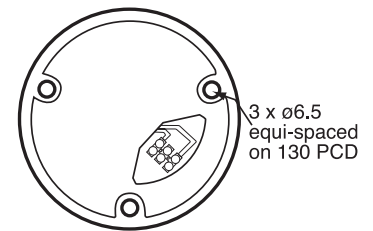
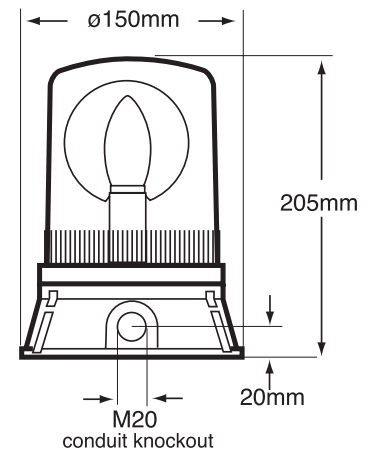

## Industrial Rotating Beacons > R401/400 Series

### Product overview

The R401/400 series beacon is a cost effective, single stage alarm, suitable for a wide range of applications where a powerful & commanding signal is required.

It incorporates a parabolic reflector which, when energised, revolves around a continuously illuminated

lamp. This creates a powerful beam of light that sweeps through 360 degrees.

The reflector is driven by a twin belt drive system that is powered by a series wound motor for 'AC' units and a permanent magnet motor for 'DC' units. The design allows for termination inside the enclosure through the base.

## R401/400 Series > Ordering Information

Code No:	Voltage:	Light Source:	Current:
R401-13	12v Dc ---	H1 x 55w	4.70 A
R401-14	24v Dc ---	H1 x 70w	3.00 A
R401-29 •	24v Dc ---	Ba15s x 10w	0.60 A
R401-60	12v Dc ---	Ba15d x 21w	1.85 A
R401-61 •	24v Dc ---	Ba15d x 21w	0.95 A
R401-62	12v Dc ---	Ba15d x 48w	4.00 A
R401-63	24v Dc ---	Ba15d x 48w	2.00 A
R401-64	48v Dc ---	Ba15d x 35w	0.75 A
R400-03	24v Ac ~	Ba15d x 48w	2.00 A
R400-02	48v Ac ~	Ba15d x 35w	0.75 A
R400-04	115v Ac ~	E14 x 60w	0.55 A
R400-05	230v Ac ~	E14 x 60w	0.29 A

• Diode Polarised for Fire Alarm Systems

ADD THE FOLLOWING LENS CODES TO THE PRODUCT WHEN ORDERING



### Features

- Continuously rated
- Suitable for surface and wall mounting
- Optional wall bracket & guard available - see accessories
- 3 point fix
- M20 conduit side entry or bottom cable entry
- Low current consumption options
- 360° light output around the vertical axis
- Dustproof and Weatherproof

### Material

UV Stable Polycarbonate Lens  
UV Stable ABS Mounting Base

Kg 0.98

50 Hz

°C -10+55

IP 65

RPM 160 Dc

RPM 120 Ac

APPROVALS and CONFORMITIES



FIRE



INDUSTRIAL