



Bracket (accessory)



Plastic bracket, adaptor for tube mounting and wire guard (accessories)

**i TECHNICAL SPECIFICATIONS/ORDER SPECIFICATIONS:**

Dimensions (Ø x Height):	142 mm x 218 mm		
Housing:	PC/ABS-Blend		
Lens:	PC, transparent		
Fixing:	Base mounting, bracket mounting, tube mounting (accessory)		
Cable entry:	Cable diameter 5-7 mm		
Connection:	Screw terminal 0.5 -1.5 mm <sup>2</sup>		
Drive:	Wheel and disc drive, motor in centre of gravity		
Halogen bulb:	G 6.35 35 W 12 V / 24 V		
Mirror rotation rate:	180 r.p.m.		
Service life of drive:	> 5,000 hrs		
Duty cycle:	100 %		

Halogen bulb included in assembly.

<b>Voltage:</b>	12 V DC	24 V AC/DC	115 V AC/DC	230 V AC
<b>Current consumption:</b>	3 A	1,6 A	0,35 A	0,17 A
red	<b>883 100 54</b>	<b>883 100 75</b>	<b>883 100 77</b>	<b>883 100 68</b>
green	<b>883 200 54</b>	<b>883 200 75</b>	<b>883 200 77</b>	<b>883 200 68</b>
yellow	<b>883 300 54</b>	<b>883 300 75</b>	<b>883 300 77</b>	<b>883 300 68</b>
blue	<b>883 500 54</b>	<b>883 500 75</b>	<b>883 500 77</b>	<b>883 500 68</b>

Further colours and voltages on request.

**ACCESSORIES:**

Plastic bracket for wall mounting	<b>975 883 06</b>
Adaptor for tube mounting	<b>975 883 09</b>
Base for tube mounting	<b>975 840 91</b>
Tube, Ø 25 mm, 100 mm long	<b>975 845 10</b>
Tube, Ø 25 mm, 250 mm long	<b>975 840 25</b>
Wire guard, only for base mounting	<b>975 883 08</b>

**SPARE PARTS:**

Halogen bulb 35 W/12 V for 230 V AC, 12 V DC, 115 V AC/DC	<b>955 883 34</b>
Halogen bulb 35 W/24 V for 24 V AC/DC	<b>955 883 35</b>

**TECHNICAL DIAGRAM:**

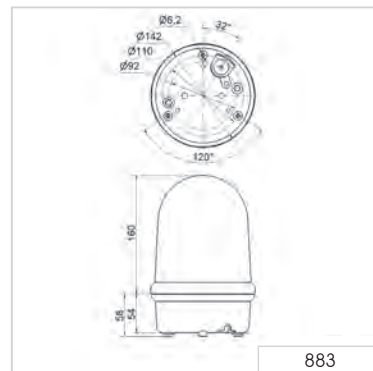

**Signalisation index**

Rotating Mirror 9

