

SMCL series

Multiple Color LED Steady/ Flashing Signal Lights

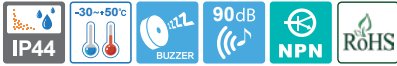

Signal lights that produces two or three multicolored LED signals

This budget model uses a multiple color LED light source to provide signals in two or three colors.



Common Specifications(SMCL80/ SMCL100/ SMCL125)

- Ideal for locations where space requirements need one warning light to convey multiple color signals
- LED light distribution system with multi-tiered reflector provides uniformed light signals throughout the entire lens
- The subdued light provides a comfortable and stable viewing condition for operation in close proximity
- Built-in buzzer available(Volume : Max 90dB at 1m)
- Can select between steady/ flashing mode
- Flashing rate : 60-80 flashes/min
- Materials : Lens-AS, Body-ABS, Reflector-Heat resistant ABS
- Ambient operating temperature : -30°C to +50°C
- Protection rating : IP44
- Certificates : CE Compliant
- Complaint with RoHS directive



SMCL80 Ø80mm Multi-Color LED Steady/ Flashing Signal Light

Model number	Voltage	Current	Certificates	Weight	Color
SMCL80	DC12V	0.234A	CE	0.18kg	<ul style="list-style-type: none"> ● R-Red ● A-Amber ● G-Green
	DC24V	0.132A		0.18kg	
	AC110V	0.066A	-	0.28kg	
	AC220V	0.033A	-	0.28kg	



SMCL100 Ø100mm Multi-Color LED Steady/ Flashing Signal Light

Model number	Voltage	Current	Certificates	Weight	Color
SMCL100	DC12V	0.387A	CE	0.23kg	<ul style="list-style-type: none"> ● R-Red ● A-Amber ● G-Green
	DC24V	0.212A		0.23kg	
	AC110V	0.093A	-	0.32kg	
	AC220V	0.046A	-	0.32kg	



Technical Diagram

(Units : mm)

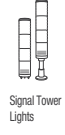
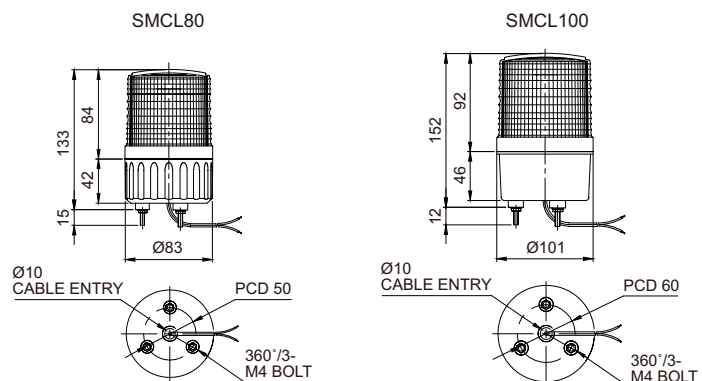

SMCL series

Multiple Color LED Steady/ Flashing Signal Lights

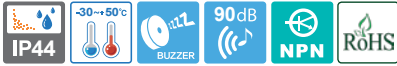

SMCL125

SMCL125 Ø125mm Multi-Color LED Steady/ Flashing LED Signal Light

Model number	Voltage	Current	Certificates	Weight	Color
SMCL125	DC12V	0.410A	CE	0.27kg	<ul style="list-style-type: none"> ● R-Red ● A-Amber ● G-Green
	DC24V	0.227A		0.27kg	
	AC110V	0.104A	-	0.36kg	
	AC220V	0.052A	-	0.36kg	



Technical Diagram

(Units : mm)

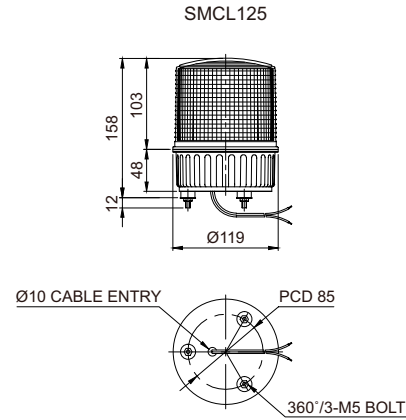

Wiring Instructions

- SMCL type can be wired with external contacts and transistor
- Wiring to transistor, use the NPN transistor. Please wire properly based on wiring instructions
- External power line standard : UL1015 AWG18(0.75sq)×2C 400mm
- External signal line standard : UL1007 AWG22(0.3sq) 400mm
- Product can be wired regardless of polarity



Wiring Instructions

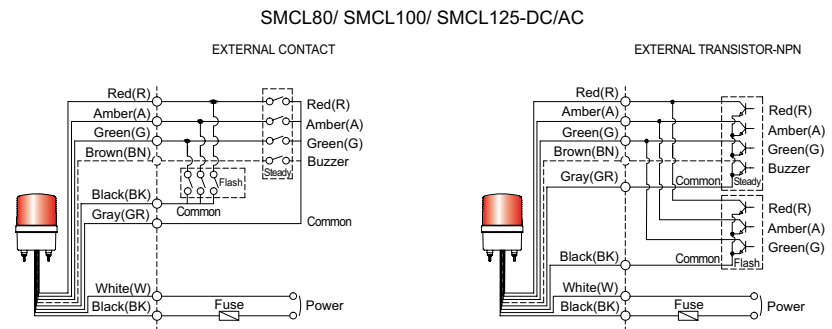

Accessories

- Wall mounting bracket options : Bracket structure allows for threading through the bracket hole or into the wall mount

- SMCL80



- SMCL100/ SMCL125

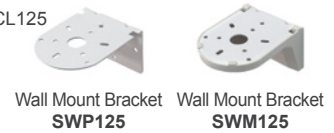

Ordering Specification

SMCL100	BZ	3	220	RAG
[Model number]	[Buzzer option]	[Colors]	[Voltage]	[Color]
<ul style="list-style-type: none"> • SMCL80 • SMCL100 • SMCL125 	<ul style="list-style-type: none"> • None • No buzzer • BZ • Built-in buzzer 	<ul style="list-style-type: none"> • 2-2colors • 3-3colors 	<ul style="list-style-type: none"> • 12-DC12V • 24-DC24V • 110-AC110V • 220-AC220V 	<ul style="list-style-type: none"> ● R-Red ● A-Amber ● G-Green