

MFL series

LED Signal Light with Multiple Light Functions



Multi-functional model with selectable steady/ flashing strobe, and simulated revolving flashing mode



MFL100



MFL125



MFL100 Ø100mm Multiple Light Function LED Signal Light

Model number	Voltage	Current	Certificates	Weight	Color
MFL100	DC12V-24V	Max 0.255A		0.30kg	<ul style="list-style-type: none"> ● R-Red ● A-Amber ● G-Green ● B-Blue
	AC110V-220V	Max 0.067A		DC only	



MFL125 Ø125mm Multiple Light Function LED Signal Light

Model number	Voltage	Current	Certificates	Weight	Color
MFL125	DC12V-24V	Max 0.255A		0.52kg	<ul style="list-style-type: none"> ● R-Red ● A-Amber ● G-Green ● B-Blue
	AC110V-220V	Max 0.067A		DC only	

※ DC type model has a free-voltage range of 10V-30V.
 ※ AC type model has a free-voltage range of 100V-240V.



Technical Diagram

(Units : mm)

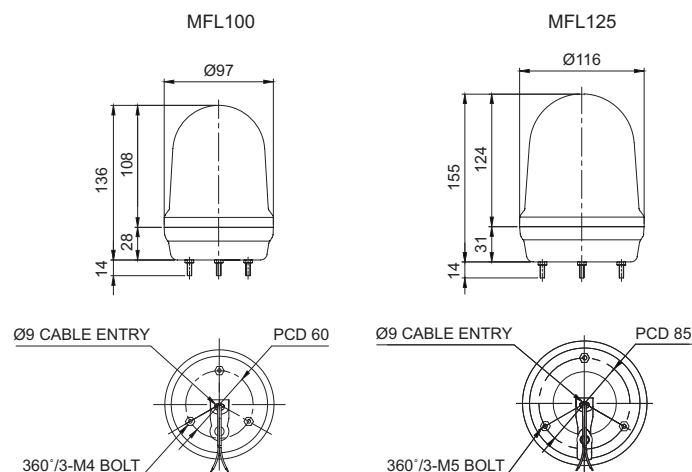

Wiring Instructions

- External power line standard : UL1015 AWG18(0.75sq)×2C 400mm
- Product can be wired regardless of polarity



Accessories

- Wall mounting bracket options : Bracket structure allows for threading through the bracket hole or into the wall mount



Ordering Specification

MFL100	-	BZ	-	110/220	-	R
[Model number]		[Buzzer option]		[Voltage]		[Color]
<ul style="list-style-type: none"> • MFL60 • MFL80 • MFL100 • MFL125 		<ul style="list-style-type: none"> • None - No buzzer • BZ - Built-in buzzer 		<ul style="list-style-type: none"> • 12/24 -DC12V-24V • 110/220 -AC110V-220V 		<ul style="list-style-type: none"> ● R-Red ● A-Amber ● G-Green ● B-Blue