

S80 series

Ø80mm Bulb Revolving Warning Lights

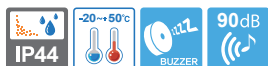

S80AU Bulb Revolving Warning Lights

- Equipped wall mount allows for easy assembly. Additional mounting brackets not required
- Terminal block designed inside the side mount bracket enables easy wiring
- Built-in buzzer available (Volume : Max 90dB at 1m)
- Revolving speed : 120-140RPM
- Materials : Lens-AS, Housing-ABS, Reflector-Heat resistant ABS
- Ambient operating temperature : -20°C to +50°C
- Protection rating : IP44

Specifications

Model number	Voltage	Current	Bulb			Certificates	Weight	Color
			Spec	Standard	Parts no			
S80AR S80AU	DC12V	0.484A	12V5W	T16x35 15S	5	-	0.31kg	<ul style="list-style-type: none"> ● R-Red ● A-Amber ● G-Green ● B-Blue
	DC24V	0.310A	24V5W	T16x35 15S	6		0.31kg	
	AC110V	0.080A	12V5W	T16x35 15S	5		0.50kg	
	AC220V	0.040A	12V5W	T16x35 15S	5		0.50kg	

Technical Diagram

(Units : mm)

S80AU

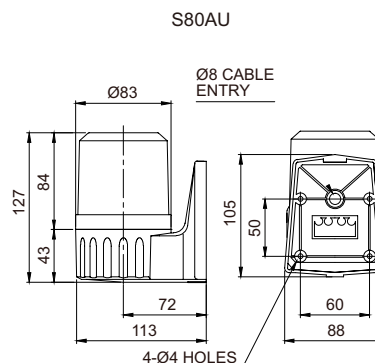

S80A series enable easy wiring

S80A series enables easy wiring with its terminal block attached to the fixed base plate. With this system the contacts in the housing sends power directly to the terminal block.

Wiring Instructions

- Attach the power supply wire to the terminal block
- DC Type : Black output line is negative(-)

Mounting Instructions

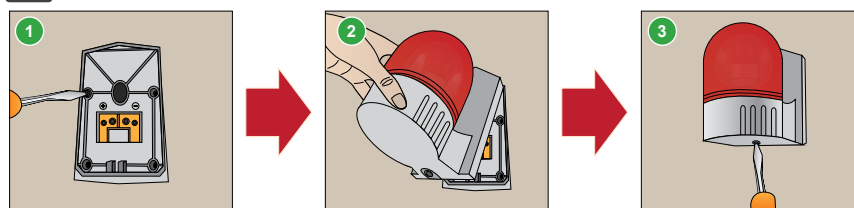

- 1 Secure the base plate to the mounting surface, and the power line to the terminal block
- 2 Mount the warning light by inserting the ring(hook) into the upper part of the base plate
- 3 Screw in the bolt at the base of the mounting bracket to complete assembly

Ordering Specification

S80AR	-	BZ	-	220	-	R
[Model number]		[Buzzer option]		[Voltage]		[Color]
<ul style="list-style-type: none"> • S80AR • S80AU 		<ul style="list-style-type: none"> • None - No buzzer • BZ - Built-in buzzer 		<ul style="list-style-type: none"> • 12-DC12V • 24-DC24V • 110-AC110V • 220-AC220V 		<ul style="list-style-type: none"> ● R-Red ● A-Amber ● G-Green ● B-Blue