



► Model 450E

Vibratone® Electronic Horn

Model 450E electronic horn offers a loud, clear and distinctive tone. It's often used for general alarming, start and dismissal noticing, coded paging and process control in noisy areas. Its 4-wire terminal block and supervisory diodes design make it ideal for fire alarm applications.

The 450E's polycarbonate housing and polymeric speaker are corrosion resistant and weatherproof for improved durability in harsh industrial environments. It has no detectable RF emissions in a 30 MHz to 1000 MHz frequency range, which minimizes the potential for electrical device interference.

FEATURES

- Fire Regulated 16-33VDC
General Purpose Signal 12-24VDC
- Coded or sustained tones
- No duty cycle or interval limitations
- 99 dBa @ 10' on axis (109 dBa @ 1m on axis)
- Four wire terminal block and supervisory diode
- Type 4X when installed with Panel Mount Gasket (included) or optional Non-metallic Weatherproof Backbox (Model WB-NM)
- Marine Rated
- CSFM Approved
- UL and cUL Listed
- UL Fire Listed and ULC Canadian Fire Listed

MODEL	VOLTAGE	OPERATING CURRENT	DECIBELS 10'	UL 464 1M	DECIBELS ON AXIS 10'	ON AXIS 1M
450E-024	Fire Regulated 16-33VDC	0.25 amps	90	109	99	109
	General Purpose Signal 24VDC	0.22 amps	N/A	N/A	99	109
	General Purpose Signal 12VDC	0.12 amps	N/A	N/A	94	104

Vibratone® Electronic Horn (450E)

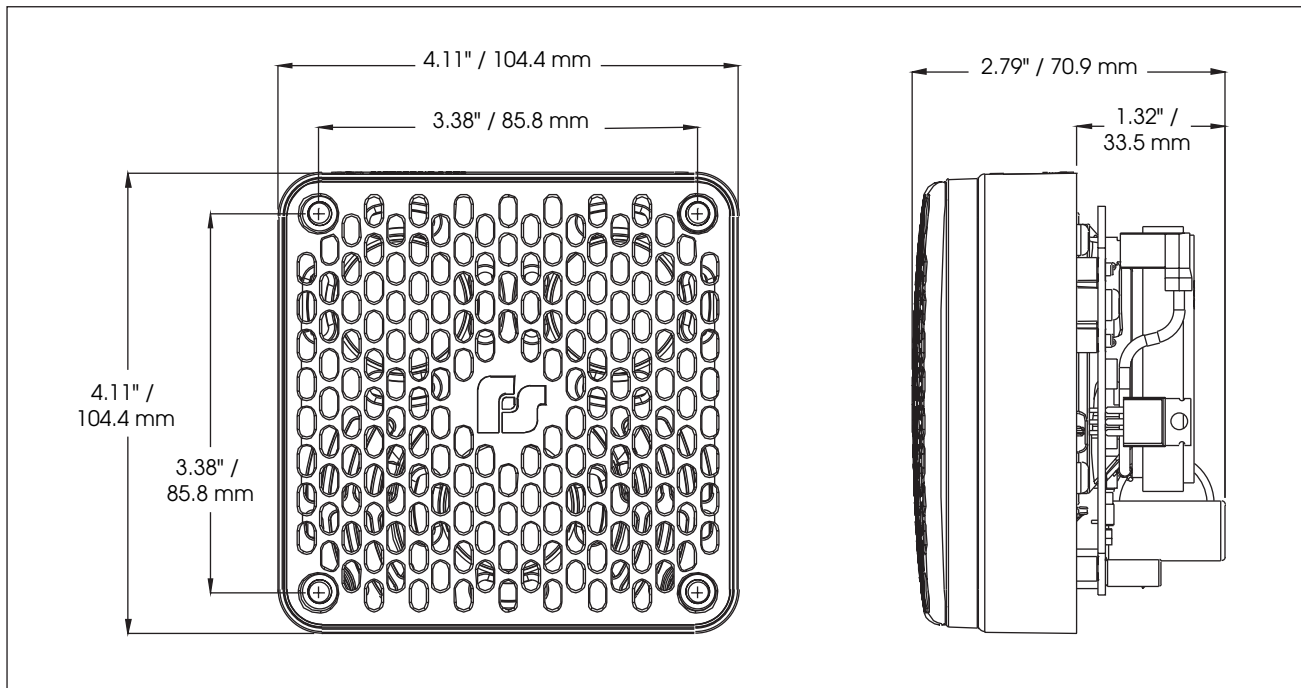

SPECIFICATIONS

Operating Temperature:	-65°F to 150°F	-54°C to 66°C
Housing:	Non-metallic Polycarbonate Light Gray (RAL 7035)	
Net Weight:	1.0 lbs	0.45 kg
Shipping Weight:	1.3 lbs	0.59 kg
Height:	4.11"	104.4 mm
Width:	4.11"	104.4 mm
Depth:	2.79"	70.9 mm

HOW TO ORDER

Specify Model:
450E-024 – Vibratone® Electronic Horn

OPTIONAL ACCESSORIES

Description	Part Number	Description	Part Number
Wall box for flush mounting the Vibratone® horn in stud, 4" block, or other shallow wall construction; 4-3/8" square box; 2-7/8" deep; shipping weight 2 lbs (0.91 kg)	FB	Non-metallic double projector directs sounds to both sides when attached to 350/450E models; ideal for use in hallways; 4" H x 11-1/2" W x 4" D; shipping weight 1 lb (0.45kg)	PR2-NM
Same as FB, but 3-13/16" deep for 6" x 8" concrete block, cinder block or other deep wall construction; shipping wt. 3 lbs (1.36 kg)	FBL	Molded thermoplastic neoprene-gasketed weatherproof housing for outside use, complete with mounting lugs; provided with (3) entrances for 1/2" conduit; 4-3/8" square box; 2-7/16" deep, offset mounting lugs on 5" centers; shipping weight 1 lb (0.45kg)	WB-NM
Flush grille which attaches to the basic unit and serves as the cover of the plastered-in FB flush box; 6" H x 6" W x 1/8" D; shipping wt. 1 lb (0.45 kg)	FG		

