

EQ100



EQ100

PRODUCT SPECIFICATION

EQ100

Materials Lens-PC, Housing-ABS
Ambient operating temperature -30°C to +50°C
Volume Max.90dB at 1m(Built-in buzzer type)
Protection rating IP44
Simulated revolving type(LR) flashing rates 120-140RPM
Strobe type(LS) flashing rates 70-80/min
Compliant with RoHS directive

- Standard-sized signal lights of Ø100mm with attractive appearance
- Direct mount type with the three bolts/screws located on the bottom of the product
- Shock and vibration-resistant, maintenance reduced with long-lasting energy efficient LED light
- Features high visibility with special diffusive lens and direct LED light distribution system

Manual switch to select operation

Please refer to the chart below to use light function selection switch located inside the product.

ON=1	<input type="checkbox"/>	Light function
OFF=0	<input type="checkbox"/>	
ON		LED Strobe
OFF		LED Simulated revolving flashing

Operation



LED Simulated Revolving
 LEDs flash steadily around the cylindrical LED filaments which makes a simulated revolving effect

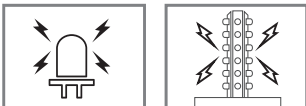

LED Strobe
 Short LED Steady/ Flashing cycle. Creates a xenon flashing effect by providing maximum electric current

EQ100 Ø100mm Steady/Flashing, strobe beacon light

Model number	Voltage	Current	Certificates	Weight	Color
EQ100	DC24V	Max.0.085A	-	0.30kg	● R-Red ● A-Amber ● G-Green ● B-Blue
EQ100-BZ	AC220V	Max.0.140A			

※ LR(Simulated revolving)/ LF(Flashing) type is available.

Technical Diagram

Units: mm

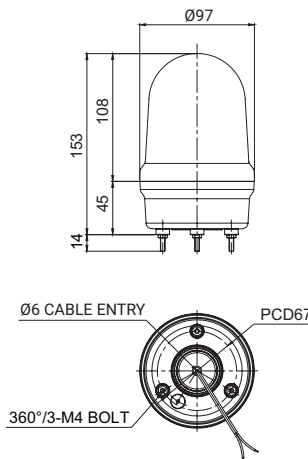

Wiring Instructions

- External Power line - UL1015 AWG18(0.75sq) x 2C 400mm
- DC Type: Black output line is negative(-)

Ordering Specification

EQ100	-	BZ	-	24	-	R
[Model number]		[Buzzer option]		[Voltage]		[Color]
EQ100		None		24-DC24V		● R-Red
EQ100-BZ		- No buzzer		220-AC220V		● A-Amber
		BZ				● G-Green
		- Built-in buzzer				● B-Blue