

S100 series

Ø100mm Bulb Revolving Signal Lights

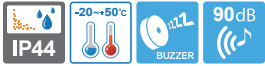

S100U



S100UA

Enhanced diffusion through a special 12 sided diffusive lens

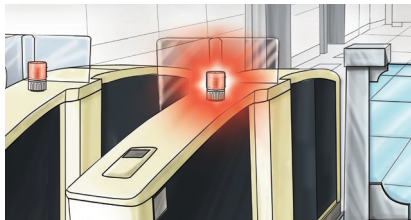

S100U set on 1st floor security gate of public office for disabled persons.

S100U/ S100UA Bulb Revolving Signal Lights

• Protection rating : IP44

Model number	Voltage	Current	Bulb			Certificates	Weight	Color
			Spec	Standard	Parts no			
S100U	DC12V	0.966A	12V10W	T16x35 15S	9	CE	0.36kg	<ul style="list-style-type: none"> ● R-Red ● A-Amber ● G-Green ● B-Blue
	DC24V	0.566A	24V10W	T16x35 15S	10		0.36kg	
S100UA	AC110V	0.130A	12V10W	T16x35 15S	9		0.59kg	
	AC220V	0.065A	12V10W	T16x35 15S	9		0.59kg	



Technical Diagram

(Units : mm)

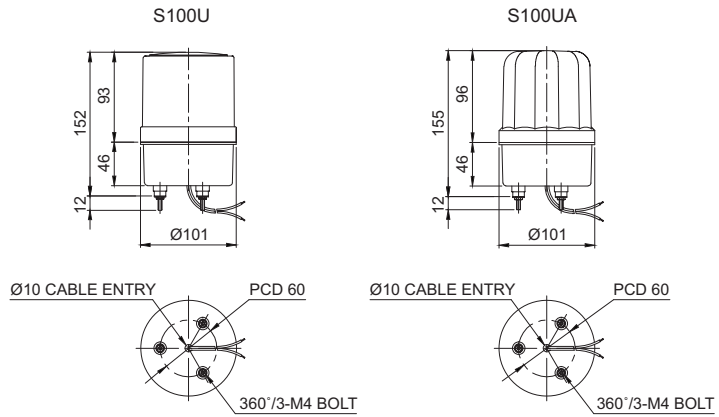

Wiring Instructions

- External power line standard : UL1015 AWG18(0.75sq)×2C 400mm
- DC type : Black output line is negative(-)



Customization

- 2 buzzer sound types : Both prolonged(beep, beep) and staccato(beep, beep, beep) buzzer output available

- Product used dome type lens (Model number : S100UR)

- Wall mount bracket options : Bracket structure allows for threading through the bracket hole or into the wall mount



S100UR



Wall Mount Bracket
SWP125



Wall Mount Bracket
SWM125



Ordering Specification

S100U	-	BZ	-	220	-	R
[Model number]		[Buzzer option]		[Voltage]		[Color]
<ul style="list-style-type: none"> • S100U • S100UA 		<ul style="list-style-type: none"> • None - No buzzer • BZ - Built-in buzzer 		<ul style="list-style-type: none"> • 12-DC12V • 24-DC24V • 110-AC110V • 220-AC220V 		<ul style="list-style-type: none"> ● R-Red ● A-Amber ● G-Green ● B-Blue